

Fitting Instructions

Revo Intake Upgrade Kit 2.3 Mustang EcoBoost

Fitting Difficulty



Dealer Fit Recommended

Contents

Description	
Revo Intake Pipe	1
Revo Intake Hose	1
Revo Air Filter	1
Revo Heatshield	1
Heatshield Lid	1
Heatshield Gasket	1
Heatshield Gasket Plate	1
Intake Pipe Bracket	1
M5x15 Button Head Bolt	9
M5 Washer	14
M5 Nylock Nut	5
M8x12 Captive Head Bolt	1
M12x30 Hex Head Bolt	2
100-120 Hose Clamp	2
50-70 Hose Clamp	1
M12 Flat Washer	2
M8 Flat Washer	1

Recommended Tools

Tools	Size
Ratchet	
Sockets	7, 8, 10, 13, 19mm
Hex Key	3, 5mm
Tension Clamps Pliers	



Before starting, please ensure that the battery is disconnected and you have ensured the engine is cool. Engine temperatures can remain high for a substantial amount of time after use.

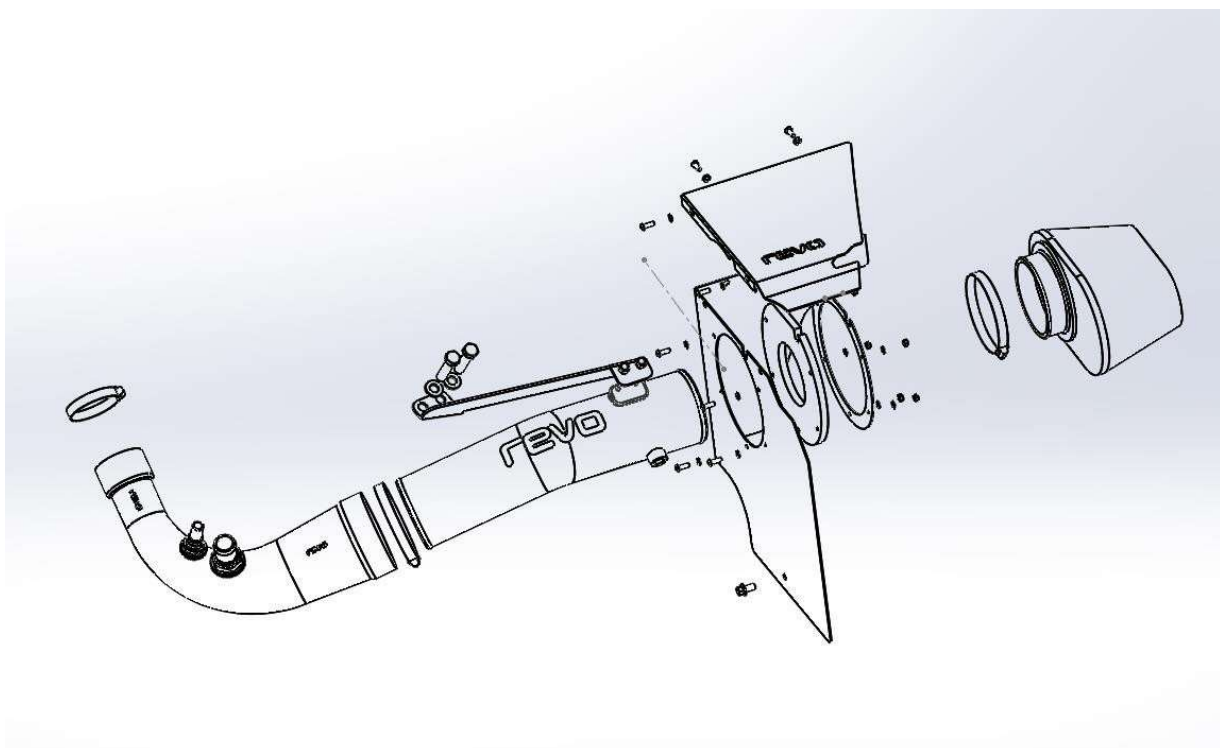

Fitting Instructions

Revo Intake Upgrade Kit 2.3 Mustang EcoBoost

Fitting Difficulty



Dealer Fit Recommended

- 1 Remove the 2 x M10 nuts and M8 bolts and remove the engine cover.

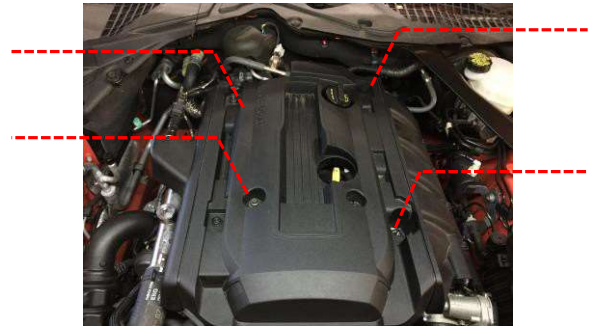

- 2 Unclip the sensor from the pipe and loosen the hose clamp on the airbox.

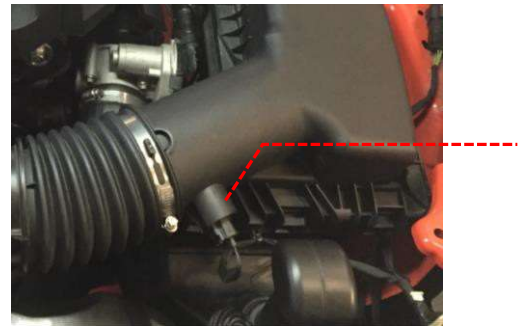

- 3 Remove the M10 bolt at the side of the airbox, keep safe as you will reuse this later.



- 4 Loosen the hose clamp on the turbo inlet hose.



Fitting Instructions

Revo Intake Upgrade Kit 2.3 Mustang EcoBoost

Fitting Difficulty



Dealer Fit Recommended

- 5 Remove and unclip the 2 x pipes on the OE intake pipe.

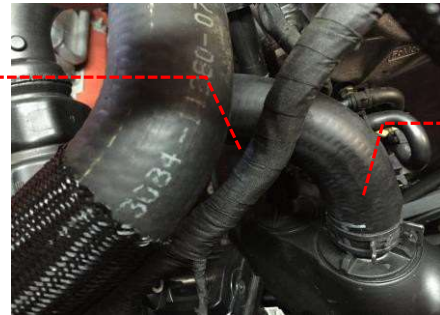

- 6 Remove the intake pipe from the airbox and the turbo then remove from the vehicle. Next, remove the airbox by pulling upwards to release from the rubber mount, slide back and then out.

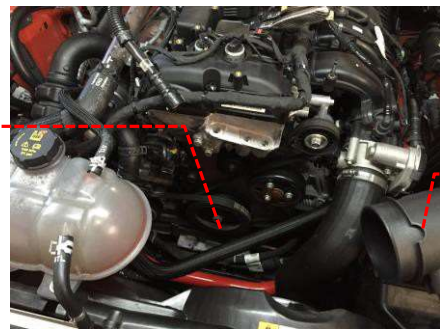

- 7 Assemble the new Revo heatshield by bolting the gasket to the inside of the heatshield with the gasket plate using 5 x M5 bolts, 10 x M5 washers and 5 x M5 nylock nuts.

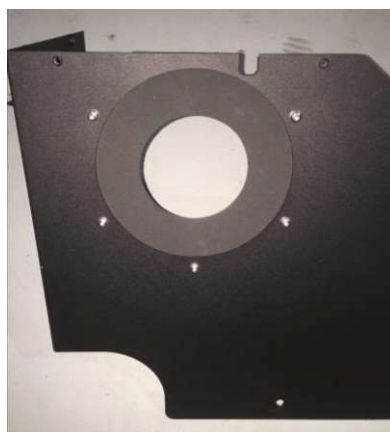

Outside view



Inside view

Fitting Instructions

Revo Intake Upgrade Kit 2.3 Mustang EcoBoost

Fitting Difficulty



Dealer Fit Recommended

- 8 Install the assembled Revo heatshield using the M10 bolt removed earlier and the M8 bolt and washer. The M10 bolt fixes the heatshield to the same location it was removed from, and the M8 bolt and washer bolt the bottom of the heatshield onto the chassis leg.

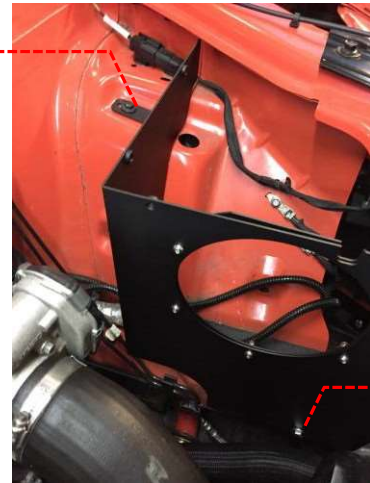

- 9 Install the new Revo intake hose using the 50-70 hose clamp, do not fully tighten yet to allow for adjustment.

- 10 Remove the sensor from the OE airbox and install into the Revo intake pipe, as shown.



Fitting Instructions

Revo Intake Upgrade Kit 2.3 Mustang EcoBoost

Fitting Difficulty



Dealer Fit Recommended

- 11 Install the Revo intake pipe using the main bracket, M12 bolts and washers, M6 pipe bolts and a 100-120 hose clamp, as shown.



- 12 Install the Revo air filter to the Revo intake pipe using the 100-120 hose clamp, as shown.



- 13 Install the heatshield lid using the M5 bolts and washers, as shown. Install all 4 x bolts and washers loosely first to allow for adjustment, then tighten. Note: ensure you place the sensor wire into the hole in the heatshield, as shown.

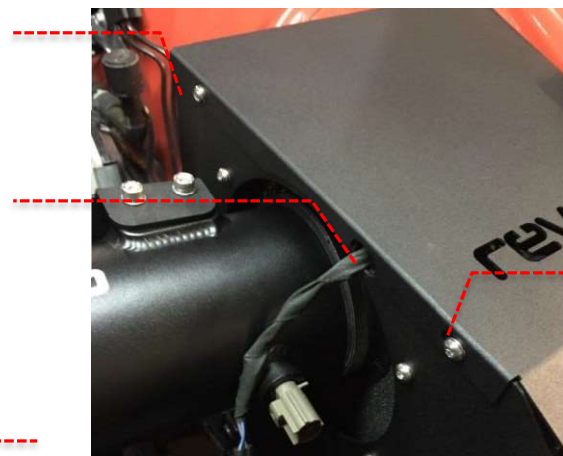

Fitting Instructions

Revo Intake Upgrade Kit 2.3 Mustang EcoBoost

Fitting Difficulty



Dealer Fit Recommended

- 14 Attach the two pipes removed from the OE intake pipe onto the two outlets on the Revo hose. Note: if necessary the outlets can be adjusted by the nut to expose more of the connector.



- 15 Reattach the sensor wiring.

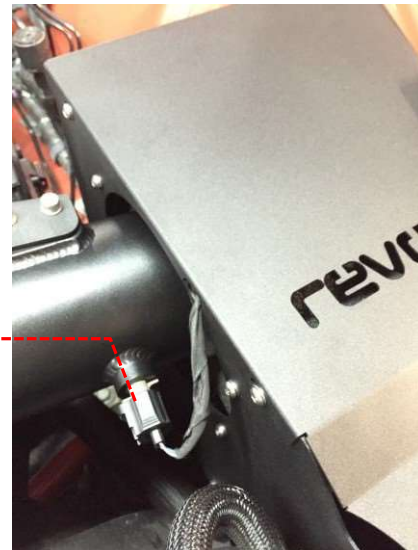

- 16 Check that all hose clamps are tight and that everything is attached correctly and refit the engine cover. Test drive the vehicle to ensure vehicle performs correctly and there are no leaks/part interference during operation. Your installation is now complete!

